

# BUILD A SOLID START

*CONCRETE MASONRY PRODUCTS*



**General Shale**

# SPECIFICATIONS

**A.**

**Concrete Masonry Units** manufactured by General Shale Products LLC's, comply with the requirements of the following specifications:

- **ASTM C90 (Latest Revision)** - Specification for Load-Bearing Concrete Masonry Units. Products are available in light weight, medium weight, and normal weight densities. The net area compressive strength of all products is in excess of 2000 psi.
- **ASTM C129 (Latest Revision)** - Specification for Non Load-Bearing Concrete Masonry Units.

**B.**

**AGGREGATES:** The aggregates from which General Shale Concrete Masonry Units are made comply with the requirements of the following specifications:

- **ASTM C331 (Latest Revision)** - Standard Specification for Lightweight Aggregate for Concrete Masonry Units.
- **ASTM C33 (Latest Revision)** - Specification for Concrete Aggregates.

**C.**

**Test Methods:** Concrete Masonry Units are tested in accordance with the tests outlined in the following standard methods:

- **ASTM C140 (Latest Revision)** - Standard Methods of Sampling and Testing Concrete Masonry Units.
- **ASTM C426 (Latest Revision)** - Standard Method for Drying Shrinkage of Concrete Block.

**NOTE:** Unless noted otherwise, all dimensions are nominal based on a  $\frac{3}{8}$ " mortar joint.  
(e.g. nominal 8" x 8" x 16" = actual 7  $\frac{5}{8}$ " x 7  $\frac{5}{8}$ " x 15  $\frac{5}{8}$ " )

# FIRE RATINGS

Concrete masonry units as manufactured by General Shale Products LLC have Fire-Resistance ratings as listed below. These ratings are based on equivalent thickness as required by the International Building Code (IBC) – 2015 Edition.

Dimensions	Block	Equivalent Thickness	Fire Resistance Rating (Hours)
12" x 8" x 16"	Bond Beam — Concrete Filled	11.63 in.	4
12" x 8" x 16"	Corner — Breaker Sash	6.46 in.	4
12" x 8" x 16"	Stretcher (Cinder or Limestone Aggregate)	5.64 in.	3.5
12" x 8" x 16"	Stretcher (Expanded Clay or Shale Aggregate)	5.64 in.	4
12" x 8" x 16"	Stretcher — Cores filled w/ vermiculate, perlite, expanded shale, clay, slate or slag aggregate	11.63 in.	4
8" x 8" x 16"	Bond Beam — Concrete Filled	7.63 in.	4
8" x 8" x 16"	Stretcher (Expanded Clay or Shale Aggregate)	3.91 in.	2.25
8" x 8" x 16"	Stretcher (Cinder or Limestone Aggregate)	3.91 in.	1.75
8" x 8" x 16"	Special Production 53% Solid	4.04 in.	2
8" x 8" x 16"	Stretcher — Cores filled w/ vermiculate, perlite, expanded shale, clay, concrete, slate or slag aggregate	7.63 in.	4
6" x 8" x 16"	Bond Beam — Concrete Filled	5.63 in.	3.5
6" x 8" x 16"	Stretcher (Cinder or Limestone Aggregate)	3.16 in.	1.25
6" x 8" x 16"	Stretcher (Expanded Clay or Shale Aggregate)	3.16 in.	1.25
6" x 8" x 16"	Solid	5.63 in.	3.5
4" x 8" x 16"	Solid	3.63 in.	1.5
4" x 8" x 16"	Stretcher (Cinder or Limestone Aggregate)	2.73 in.	1
4" x 8" x 16"	Stretcher (Expanded Clay or Shale Aggregate)	2.73 in.	1

# FILL QUANTITIES

(for Grout or Insulation)

Wall Construction		Cubic Measure of Void Volume Per 100 Square Feet of Wall Surface Area	
Item		Cubic Feet (CF)	Cubic Yards (CY)
12"	Stretchers	49.9	1.85
12"	Corner Breakers	42.9	1.59
1:1	Blend of 12" Stretchers and 12" Corner Breakers	46.4	1.72
12"	Retaining Wall Block	56.0	2.07
10"	Stretchers	34.4	1.27
8"	Stretchers	29.7	1.10
8"	Corner Breakers	27.2	1.00
2:1	Blend of 8" Stretchers and 8" Corner Breakers	28.5	1.06
8"	Retaining Wall Block	27.8	1.03
6"	Stretchers	20.7	0.77

Bond Beams & Lintels		Cubic Measure of Void Volume Per 100 Linal (Running) Feet of Beam or Lintel	
Item		Cubic Feet (CF)	Cubic Yards (CY)
12"	Bond Beam Block with Center Web	27.2	1.00
12"	Bond Beam Block without Center Web	32.9	1.22
8"	Bond Beam Block with Center Web	15.9	0.59
8"	Bond Beam Block without Center Web	21.2	0.79
8"	U-Lintel Block	16.7	0.62
6"	Bond Beam Block	21.1	0.78

**NOTE:** Quantities represent calculated volumes. No allowance has been included for waste, settlement, workmanship or other construction factors; standard pour-in insulation 4 cubic-feet per bag.

# LOADS FOR PRECAST LINTELS

(Maximum)

Masonry Opening Clear Span - (ft) LI (in)	1'-4"	2'-4"	3'-4"	4'-0"	4'-8"	5'-4"	6'-0"	6'-8"	7'-4"	8'-0"	8'-8"	9'-4"	10'-0"	10'-8"	10'-8"
Lintel Length - (ft) (in)	2'-8"	3'-8"	4'-8"	5'-4"	6'-0"	6'-8"	7'-4"	8'-0"	8'-8"	9'-4"	10'-0"	10'-8"	11'-4"	12'-0"	144"
Reinforcing Steel (Top and Bottom)	#3	#3	#3	#3	#3	#4	#4	#4	#4	#4	#4	#4	#4	#4	#4
Allowable Load (lbs/linear ft) 4" Lintel (3-5/8" x 7-5/8")	790	790	790	575	405	320	240	185	140	110	90	70	55	45	45
Allowable Load (lbs/linear ft) 6" Lintel (5-5/8" x 7-5/8")	1375	1375	1375	920	650	515	385	294	230	180	140	115	90	70	70
Allowable Load (lbs/linear ft) 8" Lintel (7-5/8" x 7-5/8")	1585	1585	1585	1150	850	665	500	380	300	235	185	150	120	95	95

- Lintel capacities are based on NCMA TEK Note 17-2
- Design loads based on maximum allowable deflection =  $L/600 < 0.3$  inches
- Reinforcing Steel grade 60,  $F_y = 60$  ksi
- Masonry design strength  $f'_c = 2500$  psi
- 4" Lintels have one bar top and bottom — 6" and 8" Lintels have two bars top and bottom

NOTE: This data is provided for information only and is not intended to replace engineering where required. General Shale assumes no responsibility for use of these tables.

# STANDARD MASONRY UNITS

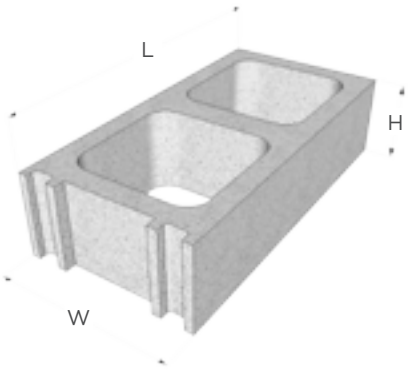

**Half High**

W	8"	12"
H	4"	4"
L	16"	16"

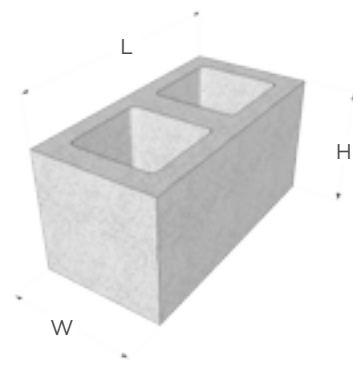

**Square End**

W	4"	6"	8"	10"	12"
H	8"	8"	8"	8"	8"
L	16"	16"	16"	16"	16"

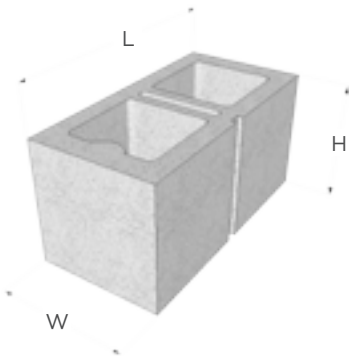

**Square End Scored**

W	4"	6"	8"	10"	12"
H	8"	8"	8"	8"	8"
L	16"	16"	16"	16"	16"

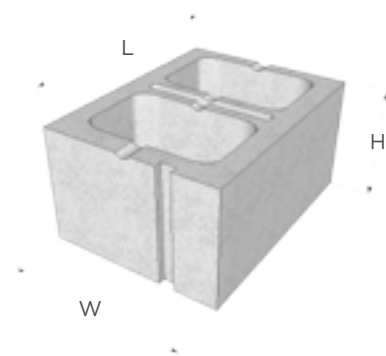

**Corner Breaker Sash**

W	6"	8"	10"	12"
H	8"	8"	8"	8"
L	16"	16"	16"	16"

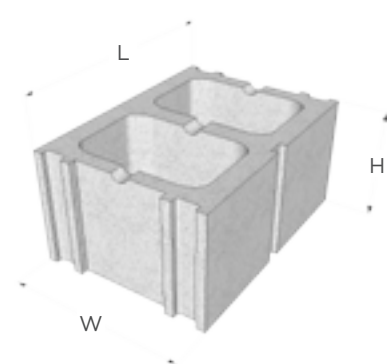

**Scored**

W	4"	6"	8"	10"	12"
H	8"	8"	8"	8"	8"
L	16"	16"	16"	16"	16"

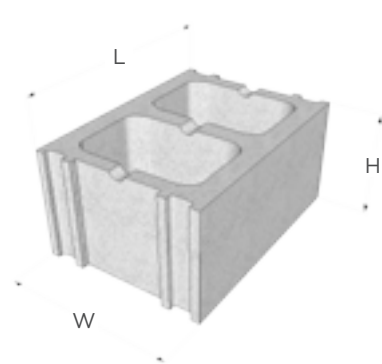

**Regular**

W	8"	10"	12"
H	8"	8"	8"
L	16"	16"	16"

**NOTE:** Unless noted otherwise, all dimensions are nominal based on a  $\frac{3}{8}$ " mortar joint.  
(e.g. nominal 8" x 8" x 16" = actual 7  $\frac{5}{8}$ " x 7  $\frac{5}{8}$ " x 15  $\frac{5}{8}$ " )

# STANDARD MASONRY UNITS

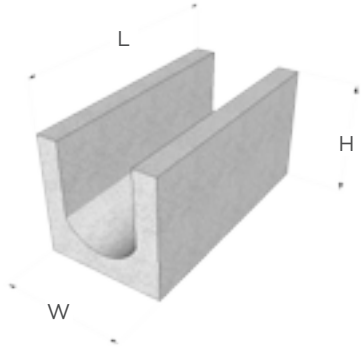

**Bond Beam**

W	6"	8"
H	8"	8"
L	16"	16"

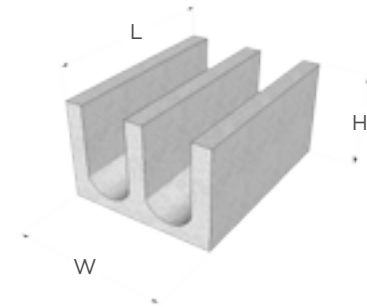

**Bond Beam**

W	12"
H	8"
L	16"

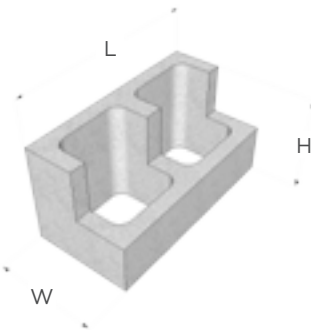

**Header**

W	8"
H	8"
L	16"

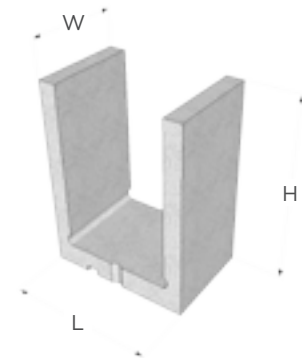

**Beam Lintel**

W	8"	12"
H	16"	16"
L	8"	8"

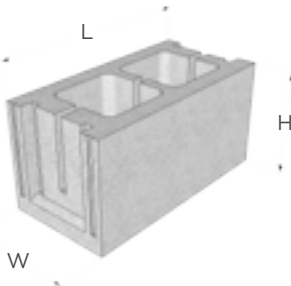

**Bond Beam Open & Solid 8"**

W	8"
H	8"
L	16"

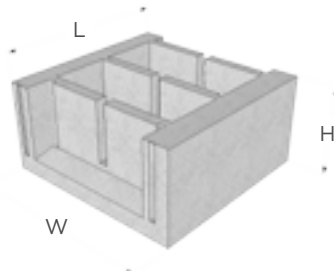

**Bond Beam Open & Solid 12"**

W	12"
H	8"
L	16"

**NOTE:** Unless noted otherwise, all dimensions are nominal based on a  $\frac{3}{8}$ " mortar joint.  
(e.g. nominal 8" x 8" x 16" = actual 7  $\frac{5}{8}$ " x 7  $\frac{5}{8}$ " x 15  $\frac{5}{8}$ " )



# STANDARD MASONRY UNITS

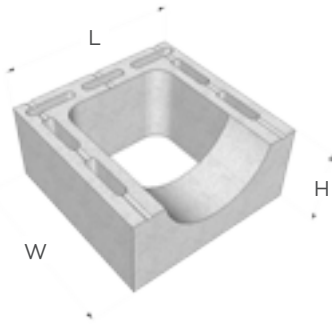

**Flue with Thimble Opening**

W	17"
H	8"
L	17"

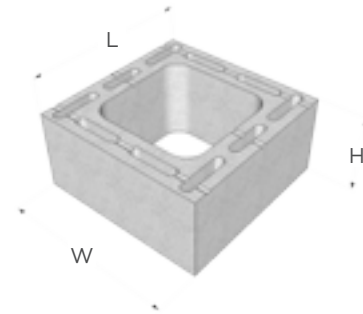

**Flue Block**

W	17"
H	8"
L	17"

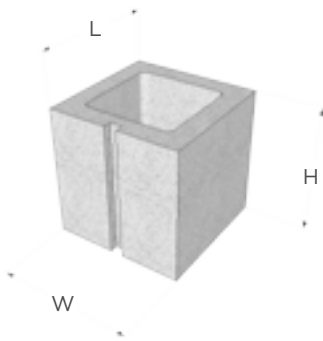

**Half Block 8"**

W	8"
H	8"
L	8"

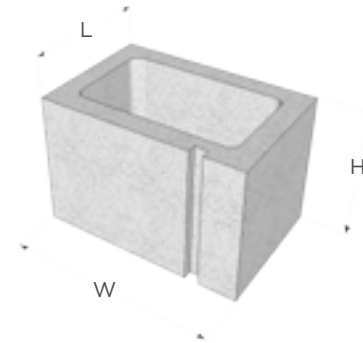

**Half Block 12"**

W	12"
H	8"
L	8"

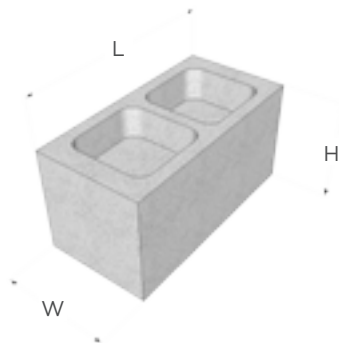

**FHA Block**

W	8"	12"
H	8"	8"
L	16"	16"

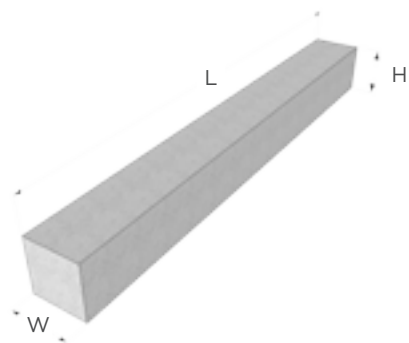

**Block Lintel**

W	4"	6"	8"
H	8"	8"	8"
L	32" – 144"		

**NOTE:** Unless noted otherwise, all dimensions are nominal based on a  $\frac{3}{8}$ " mortar joint.  
(e.g. nominal 8" x 8" x 16" = actual  $7\frac{5}{8}$ " x  $7\frac{5}{8}$ " x  $15\frac{5}{8}$ " )



# STANDARD MASONRY UNITS

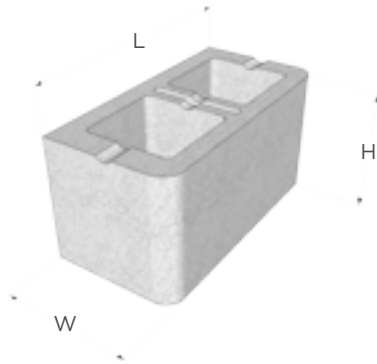

**Double Bull Nose Face**

W	4"	6"	8"	10"	12"
H	8"	8"	8"	8"	8"
L	16"	16"	16"	16"	16"

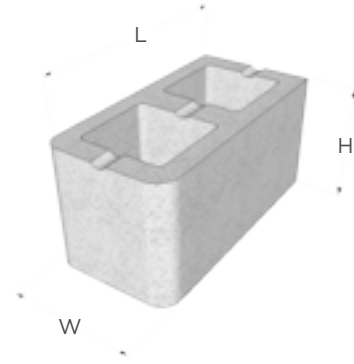

**Double Bull Nose End**

W	4"	6"	8"	10"	12"
H	8"	8"	8"	8"	8"
L	16"	16"	16"	16"	16"

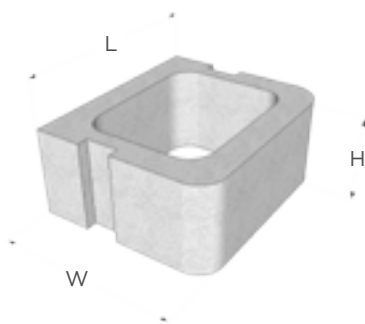

**Pilaster Block**

W	16"
H	8"
L	19"

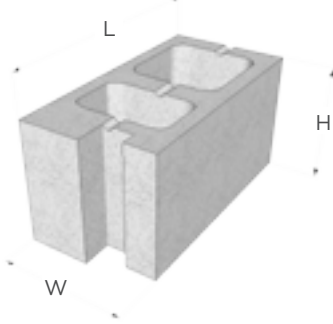

**Jamb Block**

W	8"
H	8"
L	16"

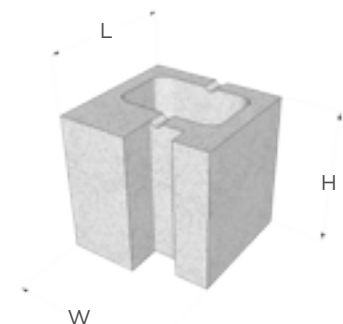

**Half Jamb Block**

W	8"
H	8"
L	8"

**NOTE:** Unless noted otherwise, all dimensions are nominal based on a  $\frac{3}{8}$ " mortar joint.  
(e.g. nominal 8" x 8" x 16" = actual 7 $\frac{5}{8}$ " x 7 $\frac{5}{8}$ " x 15 $\frac{5}{8}$ " )

# STANDARD MASONRY UNITS

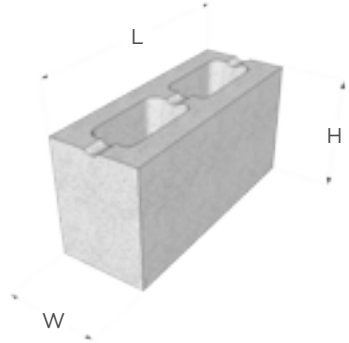

**75% Solid**

W	8"	12"
H	8"	8"
L	16"	16"

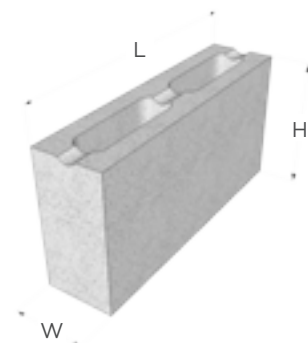

**Regular**

W	4"	6"
H	8"	8"
L	16"	16"

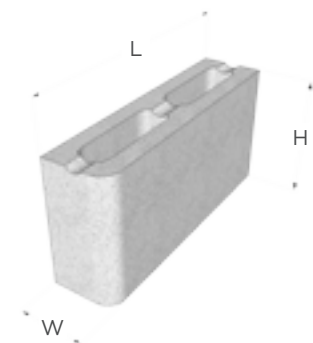

**Single Bullnose**

W	4"	6"	8"	10"	12"
H	8"	8"	8"	8"	8"
L	16"	16"	16"	16"	16"

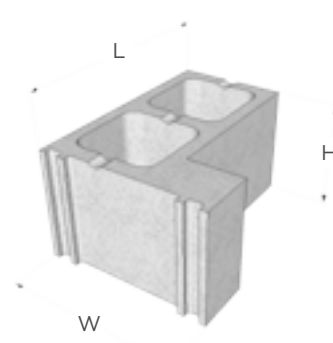

**12" Return Corner**

W	12"
H	8"
L	16"

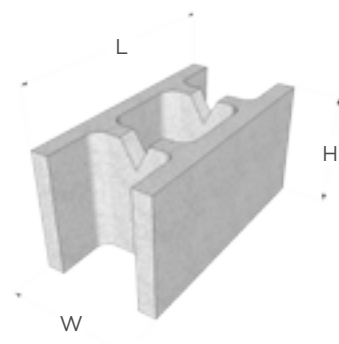

**Retaining Wall Unit 8"**

W	8"
H	8"
L	16"

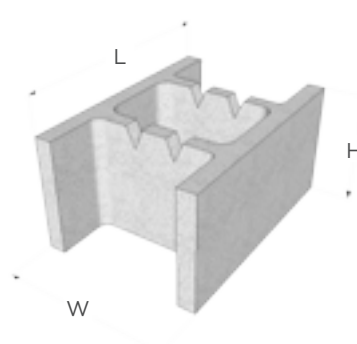

**Retaining Wall Unit 12"**

W	12"
H	8"
L	16"

**NOTE:** Unless noted otherwise, all dimensions are nominal based on a  $\frac{3}{8}$ " mortar joint.  
(e.g. nominal 8" x 8" x 16" = actual 7  $\frac{5}{8}$ " x 7  $\frac{5}{8}$ " x 15  $\frac{5}{8}$ " )

# STANDARD MASONRY UNITS

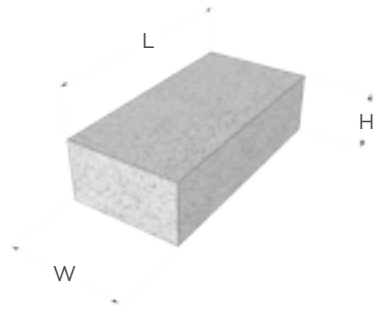

## Cinder Brick

W	4"
H	2 1/4"*
L	8"

\*Dimensions are actual

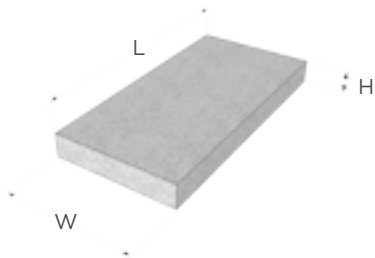

## Solid

W	8"	8"	8"	8"
H	1 5/8"*	2 1/4"*	4"	4"
L	16"	16"	12"	16"

\*Dimensions are actual

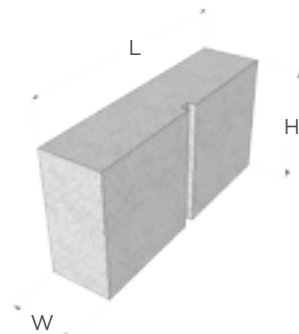

## Single Scored

W	4"
H	8"
L	16"

**NOTE: Unless noted otherwise, all dimensions are nominal based on a 3/8" mortar joint.  
(e.g. nominal 8" x 8" x 16" = actual 7 5/8" x 7 5/8" x 15 5/8")**

# SPLIT-FACED MASONRY UNITS

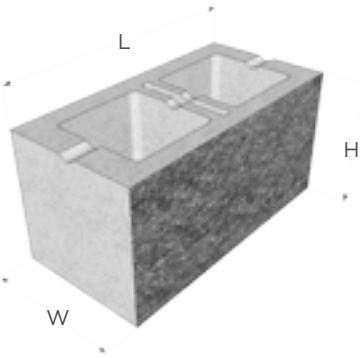

**Split-Faced Square End**

W	8"	10"	12"
H	8"	8"	8"
L	16"	16"	16"

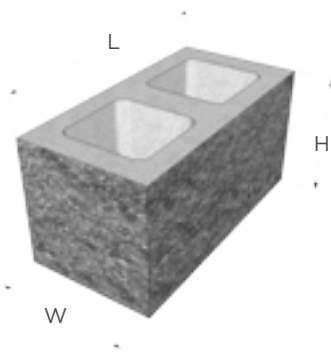

**Split-Faced Corner**

W	8"
H	8"
L	16"

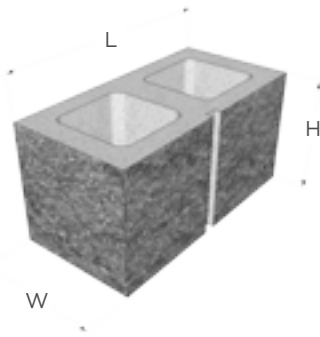

**Split-Faced Scored Corner**

W	8"
H	8"
L	16"

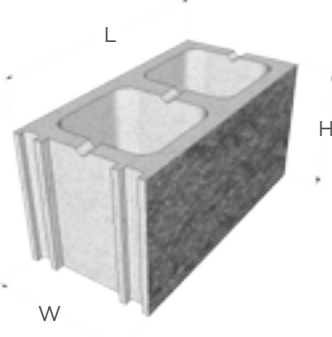

**Split-Faced**

W	8"	10"	12"
H	8"	8"	8"
L	16"	16"	16"

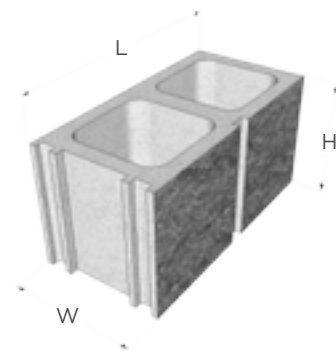

**Split-Faced Scored**

W	4"	8"	10"	12"	12"
H	8"	8"	8"	8"	8"
L	16"	16"	16"	16"	16"

**NOTE:** Unless noted otherwise, all dimensions are nominal based on a  $\frac{3}{8}$ " mortar joint.  
(e.g. nominal 8" x 8" x 16" = actual 7  $\frac{5}{8}$ " x 7  $\frac{5}{8}$ " x 15  $\frac{5}{8}$ " )

# SPLIT-FACED MASONRY UNITS

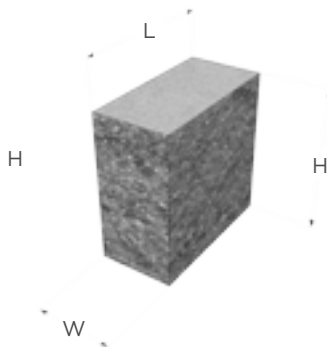

**Split-Faced End**

W	4"
H	8"
L	8"

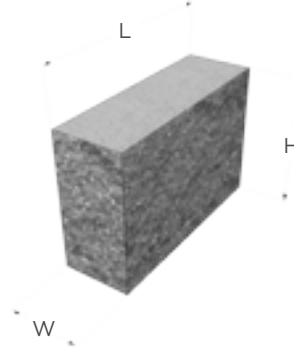

**Split-Faced End**

W	4"
H	8"
L	12"

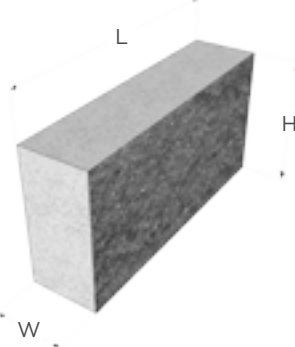

**Split-Faced**

W	4"
H	8"
L	16"

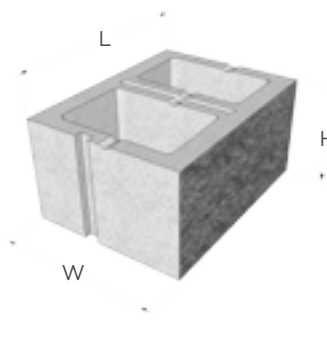

**Split-Faced End Sash**

W	8"	10"	12"
H	8"	8"	8"
L	16"	16"	16"

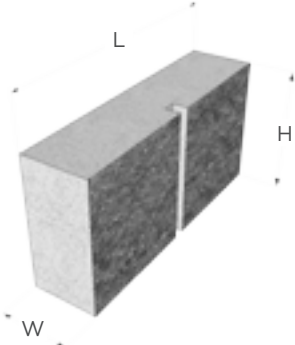

**Split-Faced Scored**

W	4"
H	8"
L	16"

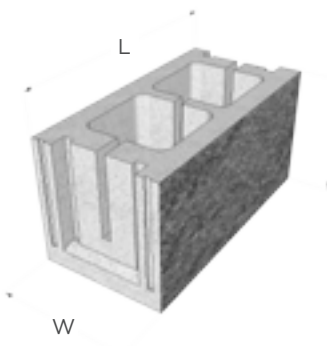

**Split-Faced Bond Beam Open & Solid 8"**

W	8"
H	8"
L	16"

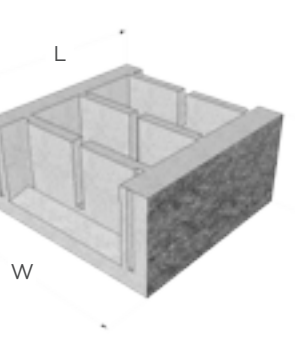

**Split-Faced Bond Beam Open & Solid 12"**

W	12"
H	8"
L	16"

**NOTE:** Unless noted otherwise, all dimensions are nominal based on a  $\frac{3}{8}$ " mortar joint.  
(e.g. nominal 8" x 8" x 16" = actual 7 $\frac{5}{8}$ " x 7 $\frac{5}{8}$ " x 15 $\frac{5}{8}$ " )

# VERSA-LOK®

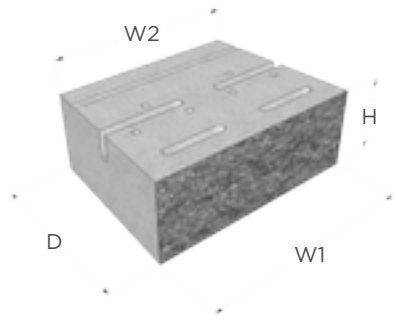

**VERSA-LOK®**  
Standard Retaining Wall System

H	6"
W1	16"
W2	14"
D	12"

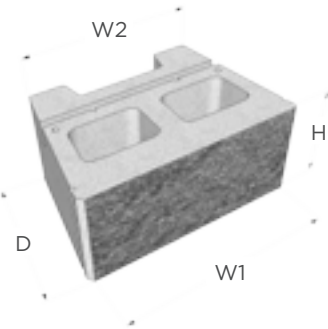

**VERSA-LOK®** Square Foot

H	8"
W1	18"
W2	16"
D	12"

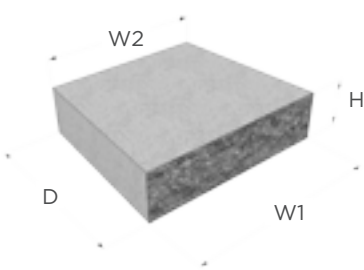

**VERSA-LOK®** A-Cap

H	3 5/8"
W1	14"
W2	12"
D	12"

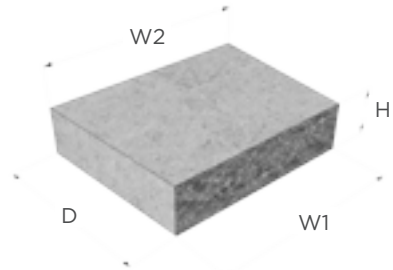

**VERSA-LOK®** B-Cap

H	3 5/8"
W1	14"
W2	16"
D	12"

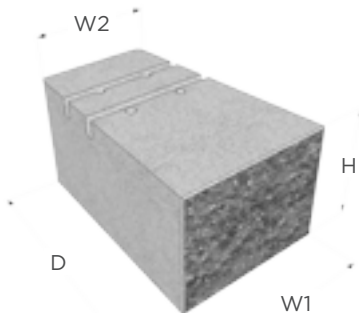

**VERSA-LOK®** Cobble

H	6"
W1	8"
W2	6"
D	12"

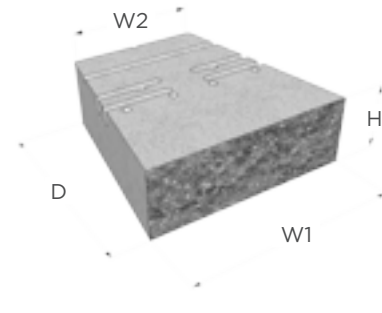

**VERSA-LOK®** Accent

H	4"
W1	12"
W2	8"
D	12"

All dimensions for VERSA-LOK® units are actual.

# GEOSTONE

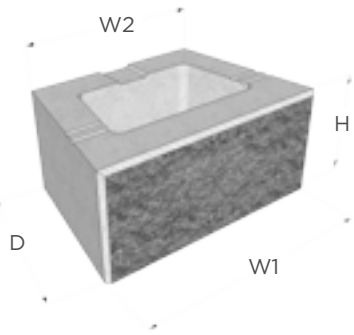

**GEOSTONE**  
**Standard Retaining Wall System**

H	8"
W1	18"
W2	13.5"
D	12"

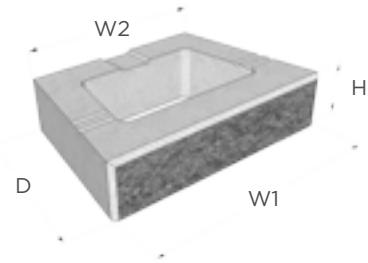

**GEOSTONE Half-High**

H	4"
W1	18"
W2	13.5"
D	12"

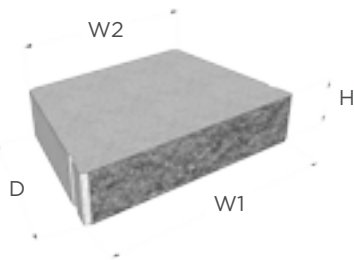

**GEOSTONE Universal Cap Block**

H	4"
W1	18"
W2	14"
D	12"

All dimensions for GEOSTONE units are actual.



# REGENCY STONE

(Concrete Veneer)

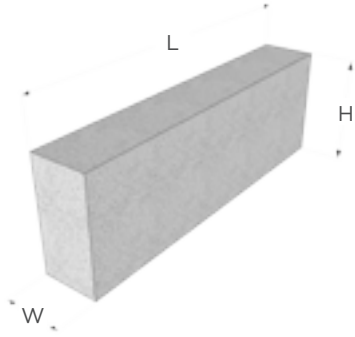

## Regency Stone Concrete Veneer

	Standard Production Sizes				Special Production Sizes			
W	4"	4"	4"	4"	4"	4"	4"	4"
H	4"	8"	12"	16"	4"	8"	4"	8"
L	24"	24"	24"	24"	12"	12"	16"	16"

**NOTE:** Unless noted otherwise, all dimensions are nominal based on a  $\frac{3}{8}$ " mortar joint.  
 (e.g. nominal 8" x 8" x 16" = actual 7  $\frac{5}{8}$ " x 7  $\frac{5}{8}$ " x 15  $\frac{5}{8}$ " )





3015 Bristol Highway | Johnson City, TN 37604 | (800) 414-4661 | [generalshale.com](http://generalshale.com)