

This technical profile illustrates many of the most common flashing details for residential and commercial buildings. The purpose for flashing is to direct moisture to the exterior and in so doing, prevent moisture from deteriorating steel angles or other building components. The following details were designed to accomplish both goals. Modifications to these details are normal, however, the changes should always focus on the primary objectives for flashing. There are some details that vary from standards practiced by the brick industry, however, it is our belief that these variations are a more practical approach.

#### THE RESPONSIBILITY FOR SPECIFYING THESE ALTERNATIVES BELONGS TO THE DESIGNER OR ENGINEER

#### **General Considerations Pertaining to Flashing Installation**

- When flashing needs splicing, the ends should be overlapped a minimum of 4" (100 mm) and sealed with a compatible mastic.
- Corner flashing also requires sealing overlapping ends.
- Watertight end dams are suggested where horizontal flashing terminates.
- Flashing generally should extend 8" (200 mm) above the bottom of the flashing and be fastened to the backup.
- Through wall flashing at the base of the walls should be located 2" or 3" (50 or 75 mm) above finished grade. In the northern climates, the brickwork should be at least 6" (150 mm) above grade.
- Any cavity space below the flashing at the wall base should be completely filled with mortar.
- When flashing is placed over a brick, block, or concrete wall adjacent to habitable rooms, a thin bed of mortar or compatible mastic must be spread onto the brick, block, or concrete walls before the flashing is set in place.
- Flashing should be noncorrosive and nonstaining. Copper and galvanized steel may stain adjacent masonry. Copper and stainless steel require a protective material when they are placed next to a steel angle.
- Impregnated felt, polyethylene, aluminum or lead should not be used as flashing.

#### **Special Considerations Pertaining to Flashing Installation**

Brick industry standards and some building codes require the flashing to project 1/4" (5 mm) past the face of the brick. This is the preferred detail, but for aesthetic reasons, this is sometimes unacceptable to brick users.

Where building codes allow, the flashing can be held back 1/2" (12 mm), provided the flashing is placed on a bed of mortar. Refer to paper by Paul Perlman on Alternative Flashing Applications to Metal Drip Edges (in Brick Veneer).

- For commercial buildings with horizontal control joints, the flashing may stop at the brick face or 1/8" (3 mm) back from the face. A second choice is to place the flashing in the mortar joint above the first brick, hold the flashing back 1/2" (12 mm) from the brick face and cover the shelf angle with a self-adhering flashing.
- For commercial and residential buildings with sills or lintels over openings, the flashing can stop 1/2" to 3/4" (12 - 19 mm) back from the brick face. Fill the core holes with mortar and spread sealant on the brick below the flashing before it is placed. The lintel detail is illustrated on detail 22. The sill detail is shown on detail 19.

#### **Advantages and Disadvantages of Elastomeric Versus Composite Flashing**

There are several generic types of through-wall flashing, specifically, rubber, metal, and composite. The most commonly used elastomeric flashing is EPDM, which normally is a cured product, manufactured in 40 mil thickness. Metal flashings are copper or stainless steel. Composite flashings come in a variety of materials. Typically they have a copper core material, covered by asphalt, kraft paper or polyethylene films. Each type has advantages and disadvantages as shown in the table below.

Elastomeric flashing is easier to bend, mold and seal at corners and end dams than composite flashing. When flashing needs to span across a cavity, composite flashing is more effective since elastomeric flashing will sag and eventually tear from sustained weight. If anchors need to penetrate the flashing, a thick elastomeric flashing will seal better around the anchor than composite flashing.

There are potential problems with the compatibility between the flashing that extends to the face of the brick and the sealant that seals the space between the underside of the flashing and the top of the brick. This note refers to detail 26 & 27.

	ADVANTAGES	DISADVANTAGES
EPDM	a. Flexible b. Easily spliced	a. Not as strong as metal or composite flashing b. Compatibility of sealant and flashing needs to be verified
Metal	a. Strong b. Can span the cavity without support c. Compatible with most sealants	a. Expensive b. Hard to splice c. May corrode when in contact with the shelf angle
Composite	a. Strong b. Can span the cavity without support	a. Expensive b. The asphalt-coated flashings are not compatible with most sealants c. Coatings may delaminate from the core

The following drawings show two possible flashing details using EPDM and the composite flashing. The first detail, below, shows a horizontal control joint using EPDM flashing material. The angle is installed with the vertical leg down so that the flashing can not tear on the anchor bolt nut. This detail could also work with metal, copper or stainless steel flashing, provided that there is a rubber or composite material separating the metal flashing from the steel angle, similar to the next detail. This flashing detail could be used with a lintel just as it is used with the shelf angle.

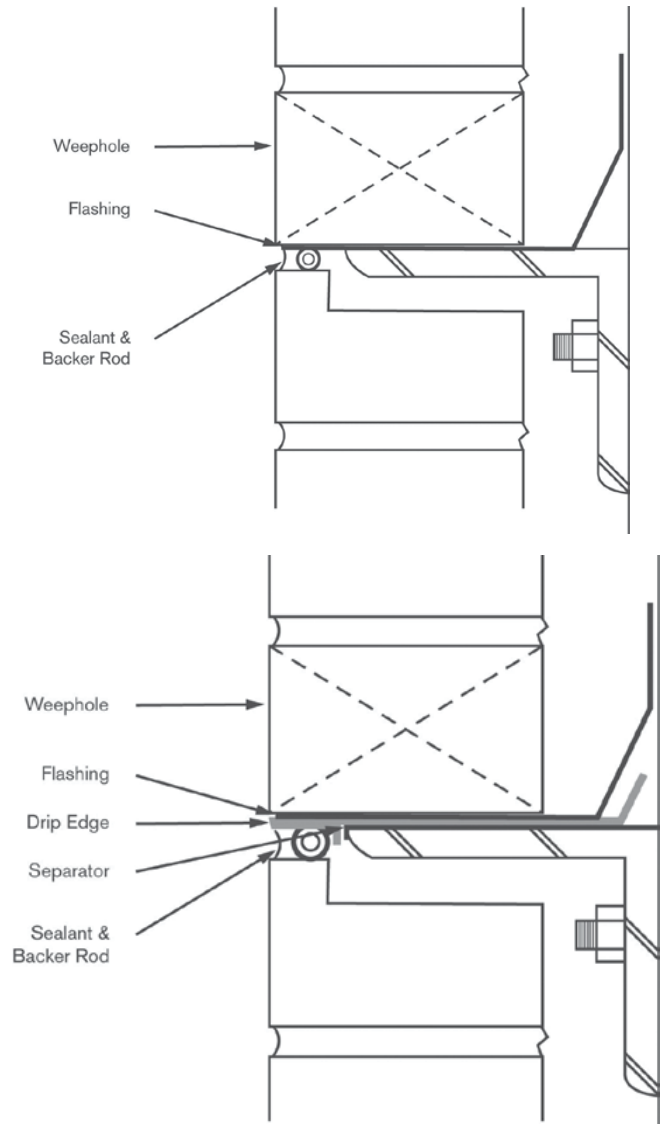

The second detail, above, also shows a horizontal control joint, but the through-wall flashing is composite flashing. Few sealants adhere effectively to bitumen coated flashing. If the flashing has kraft paper or polyethylene film, these coatings may delaminate. In order to overcome these problems, a bent metal drip edge, 12 oz. copper or stainless steel, is installed under the composite flashing so that the sealant at the brick face will have compatible surface to adhere to. In addition, the metal drip edge can not sit directly on the shelf angle; otherwise, one of the metals may corrode. Therefore, an additional piece of either rubber or composite flashing, a separator, is needed between the metal drip edge and the shelf angle. The metal drip edge can also be used with the EPDM through wall flashing.

The table below shows alternative sealants that have been tested for compatibility with different EPDM flashing materials.

The table below shows alternative sealants that have been tested for compatibility with different EPDM flashing materials.

Sealant	EPDM	
	Carlisle Pre-Kleened	Firestone Flash Guard
Pecora #895 Silicone	No Primer Necessary	P-120 Primer
Dow Corning #790 Silicone*	No Primer Necessary	No Primer Necessary

\*Does not effectively adhere to copper.

When the composite flashing sits on the metal drip edge, no sealant is needed between the two materials. When EPDM sits on the metal drip edge; Carlisle recommends "Secure Tape", Firestone recommends "Flashguard Adhesive Tape".

The sealants listed for the EPDM flashing will adhere to the drip edge and the brick. However, sealants adhere differently to different absorption rate brick, therefore, the brick adhesion should be field-tested as described below.

In addition EPDM flashing with primers applied may require adhesion testing to verify the compatibility of the sealant and the primer.

Whatever sealants are used for the horizontal, or vertical control joints, it is important that actual field-testing of the sealants adhesion to the flashing and to the brick be done.

A simple hand pull test can be used at the job site after the sealant is fully cured (usually within 7 to 21 days). It is suggested that 10 tests for the first 1,000 feet (300 m) and one test per thousand feet (300 m) thereafter or one test per floor per elevation be performed. The hand pull test procedure is as follows:

1. Make a knife cut horizontally from one side of the joint to the other.
2. Make two vertical cuts (from the horizontal cut) approximately 3" (75 mm) long, at both sides of the joint.
3. Place a 1" (25 mm) mark on the sealant tab as shown in the illustration below.
4. Grasp the 2" (50 mm) piece of sealant firmly just

beyond the 1" (25 mm) mark and pull at a 90° angle. If the sealant itself tears, then the adhesion to the flashing is adequate.

5. If dissimilar substrates are being sealed, check the adhesion of sealant to each substrate separately. This is accomplished by extending the vertical cut along one side of the joint, checking adhesion to the opposite side, and then repeating for the other surface.
6. Check with sealant manufacturer for suggested allowable extensions.

### Exterior Corner Flashing Detail - Steel & Concrete Columns - Block Backup

Note: Brick anchors & insulation have been omitted for clarity.

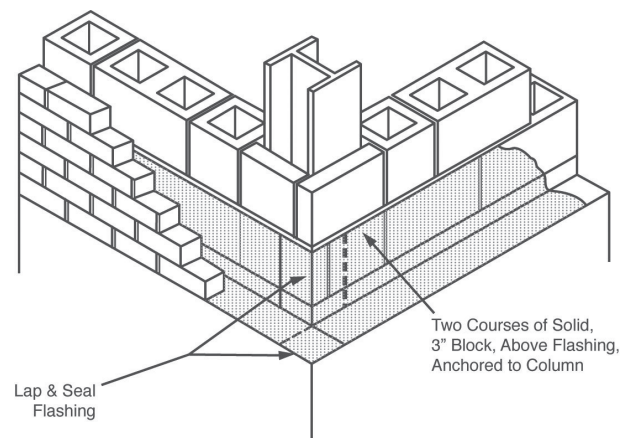

Detail 1

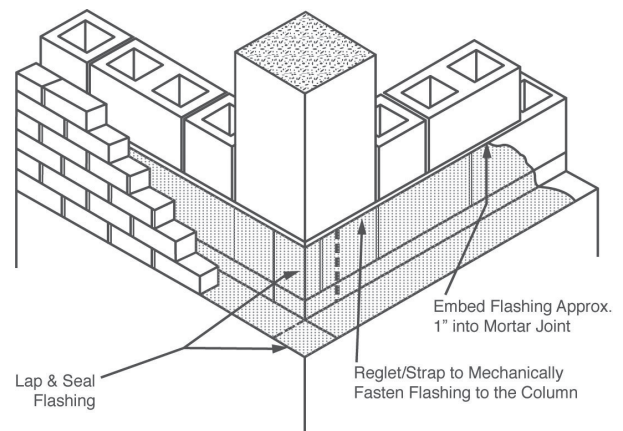

Detail 2

**Exterior Corner Flashing Detail -  
Steel Columns - Block Backup**

Note: This detail is an alternate to detail 1. Brick anchors & insulation have been omitted for clarity.

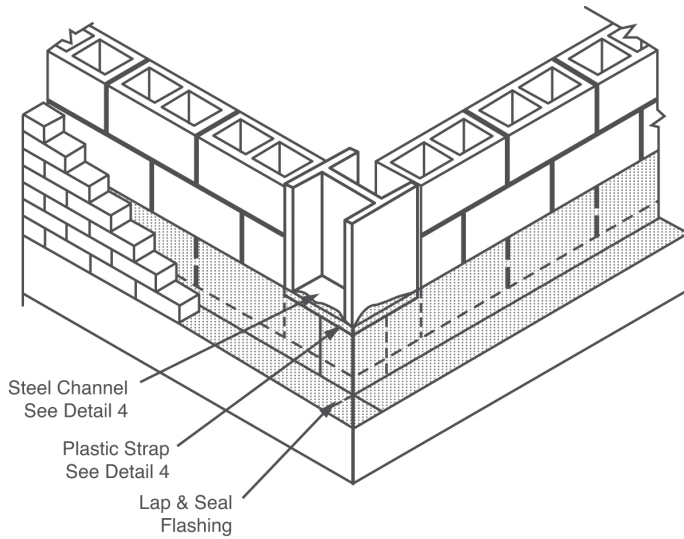

Detail 3

**Interior Corner Flashing Detail -  
Steel & Concrete Columns - Block Backup**

Note: Brick anchors & insulation have been omitted for clarity.

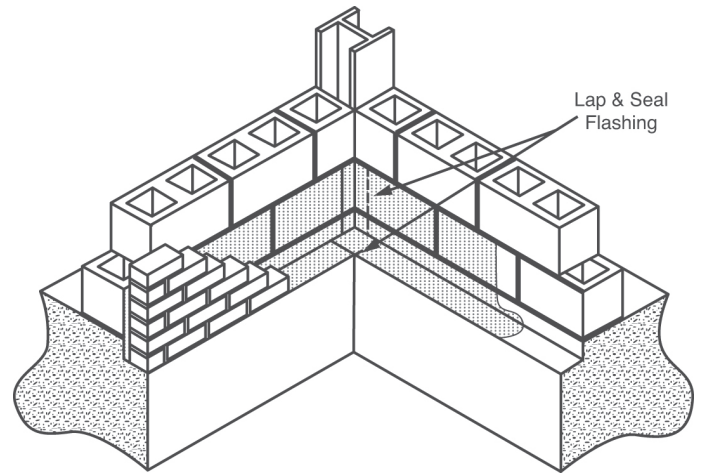

Detail 5

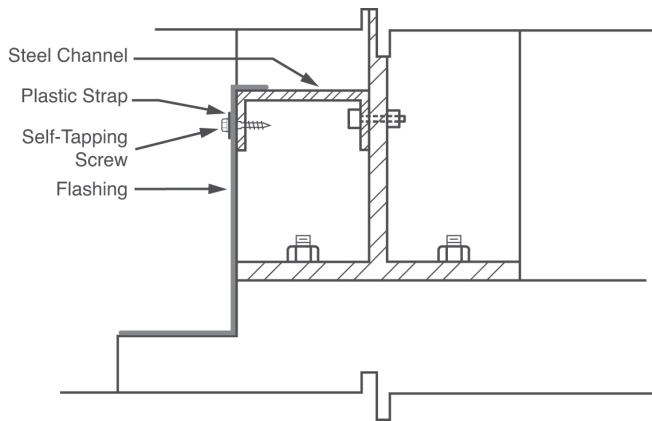

Detail 4

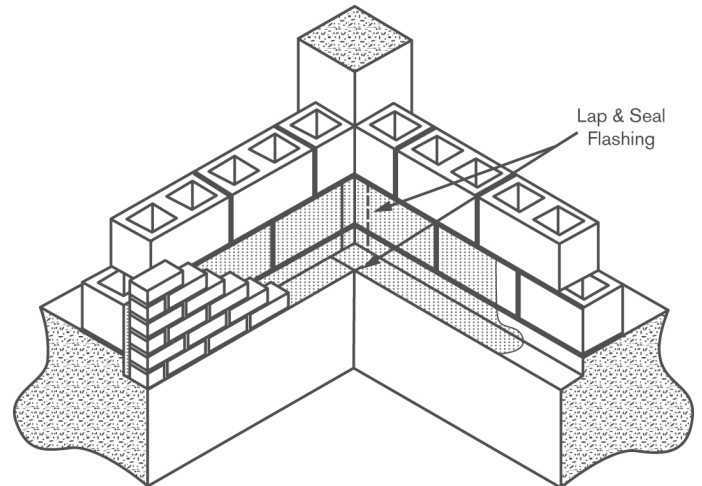

Detail 6

**Enlarged Detail of Flashing Attachment at Column Base**

Note: Same detail is used for intermediate column.



**Intermediate Column Flashing Detail -  
 Steel & Concrete Columns - Block Backup**

Note: Brick anchors & insulation have been omitted for clarity.

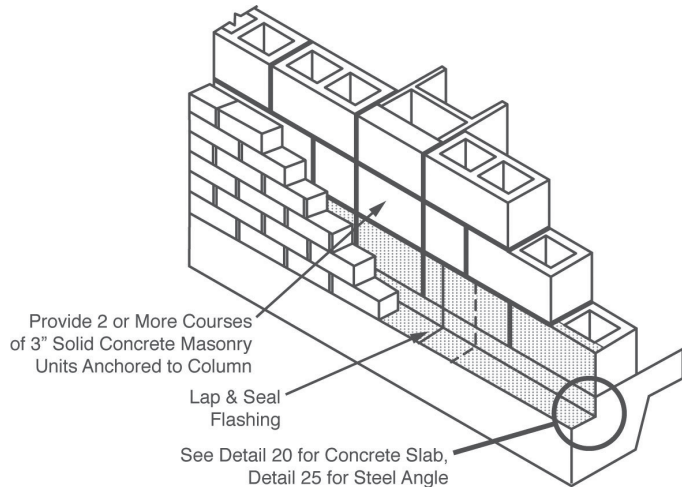

Detail 7

Note: Support for the brick may be a steel angle instead of a concrete footing. Support for the concrete block may be a concrete slab on metal decking supported by a steel beam.

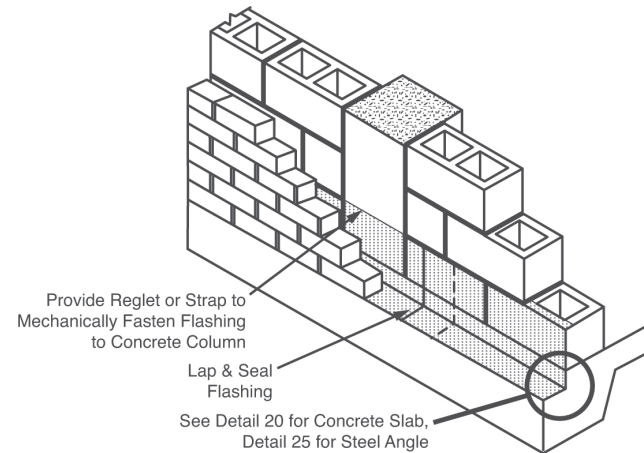

Detail 8

Note: Support for the brick may be a steel angle instead of a concrete footing.

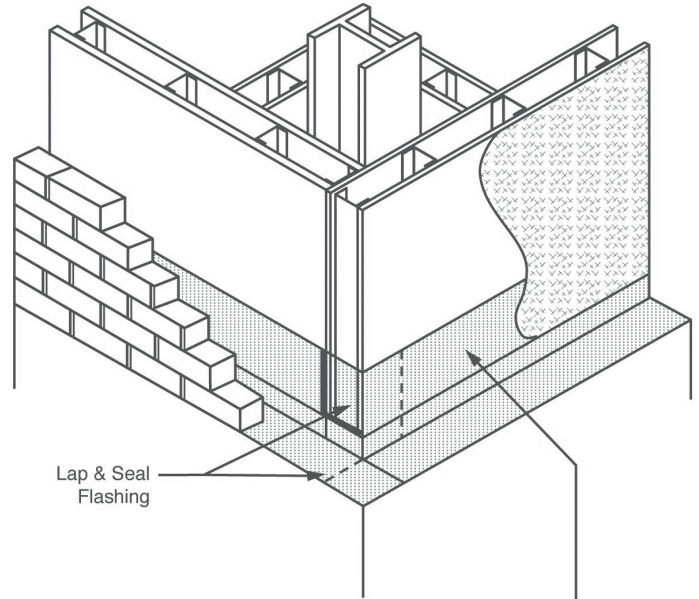
**Exterior Corner Flashing Detail -  
 Steel & Concrete Columns - Metal Studs**

Detail 9

Flashing is Placed **BEHIND** THE SHEATHING BOARD or on top of the Sheathing Board but Behind the Felt Paper, Mechanically Fastened to the Backup and Lapped as Show

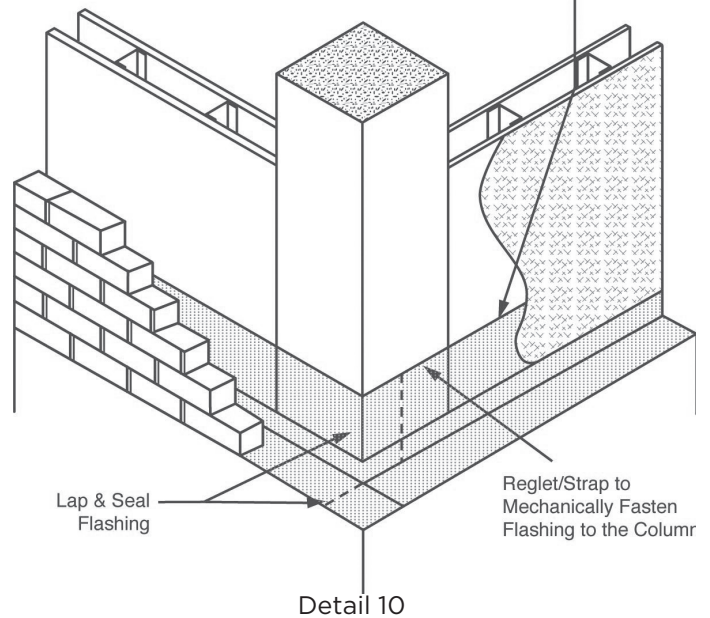

Detail 10

## Interior Corner Flashing Detail - Steel & Concrete Columns - Metal Studs

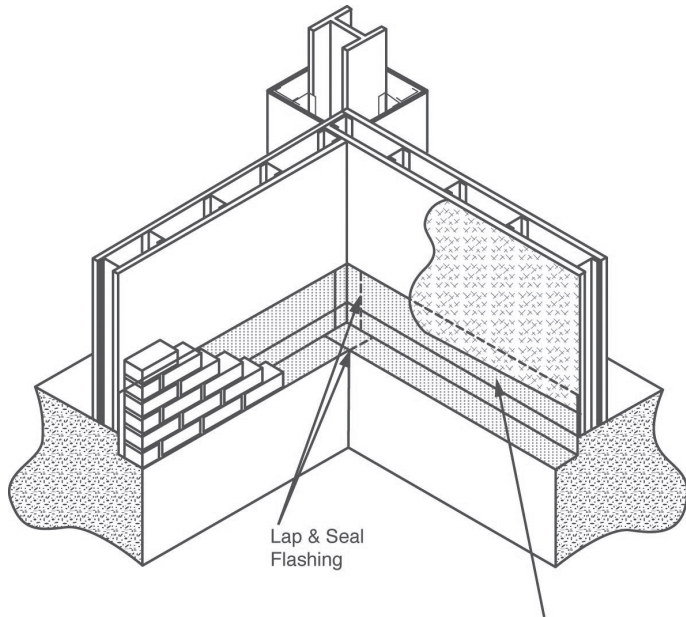

Detail 11

Flashing is Placed Behind the Sheathing Board or on top of the Sheathing Board but Behind the Felt Paper, Mechanically Fastened to the Backup with the Anchors

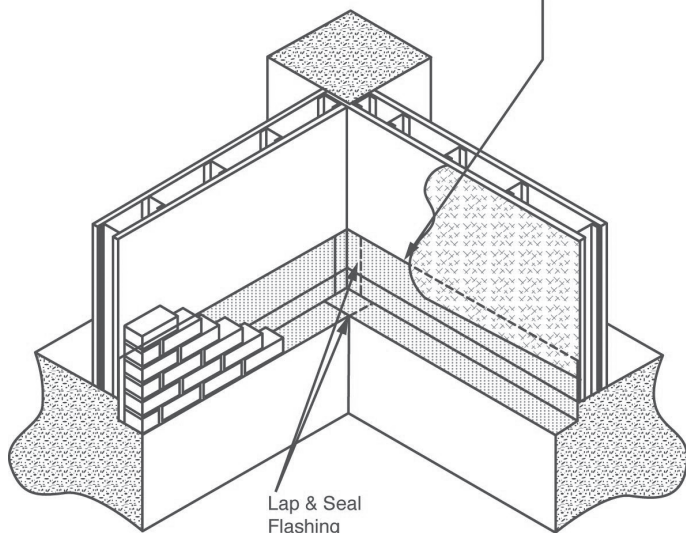

Detail 12

## Intermediate Column Flashing Detail - Steel & Concrete Columns - Metal Studs

Note: Both details have brick anchors & insulation omitted for clarity. Support for the brick may be a steel angle instead of a concrete footing. Avoid supporting steel angle from metal studs.

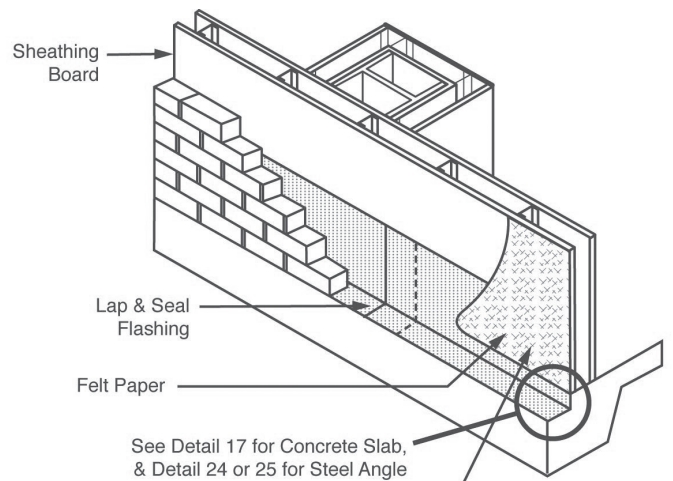

Detail 13

The Flashing may be Placed Behind the Sheathing Board or on top of the Sheathing Board but Behind the Felt Paper and Mechanically Fasten to the Backup with the Anchors

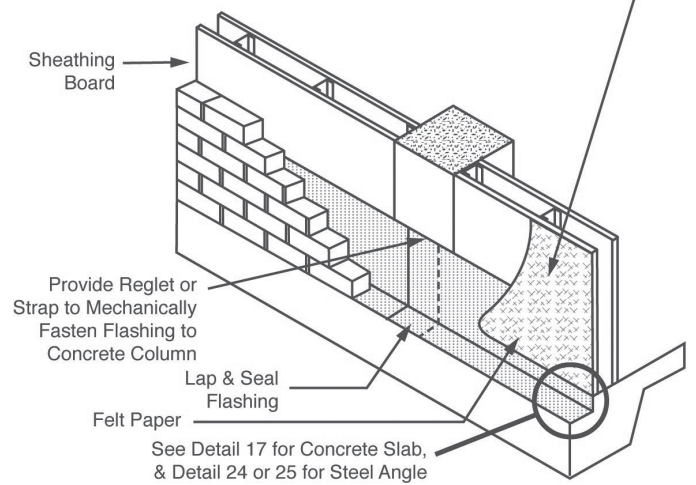

Detail 14

**Typical Flashing Details  
Brick Veneer on Steel Studs**

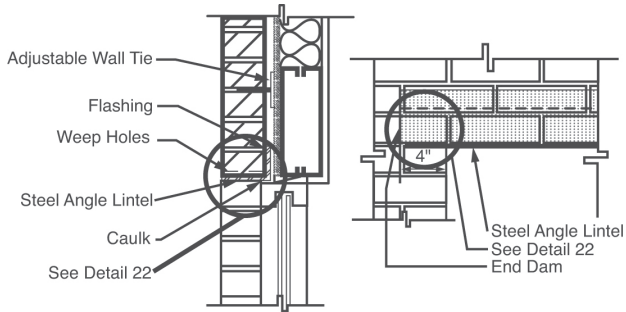

Detail 15 - Window Head w/ Loose Angle

**Typical Flashing Details  
Brick Veneer on Concrete Block**

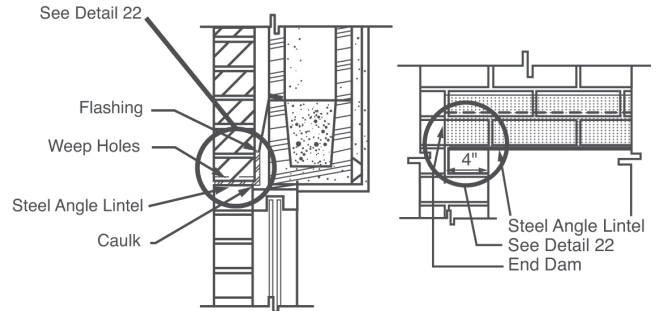

Detail 18 - Window Head w/ Loose Angle

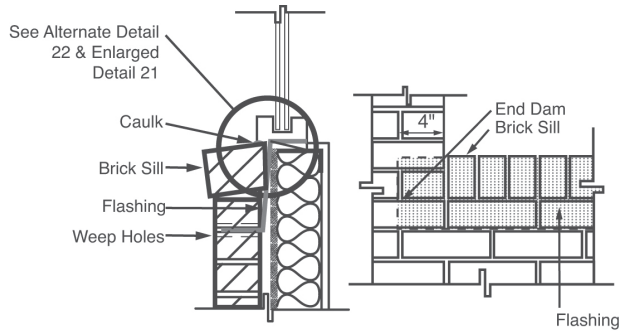

Detail 16 - Window Sill, Opening Less Than 4 ft.

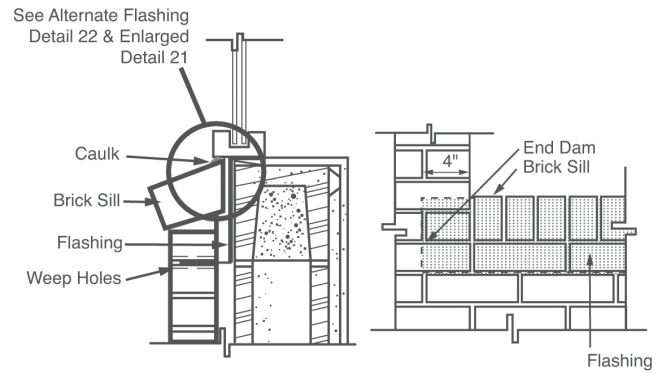

Detail 19 - Window Sill

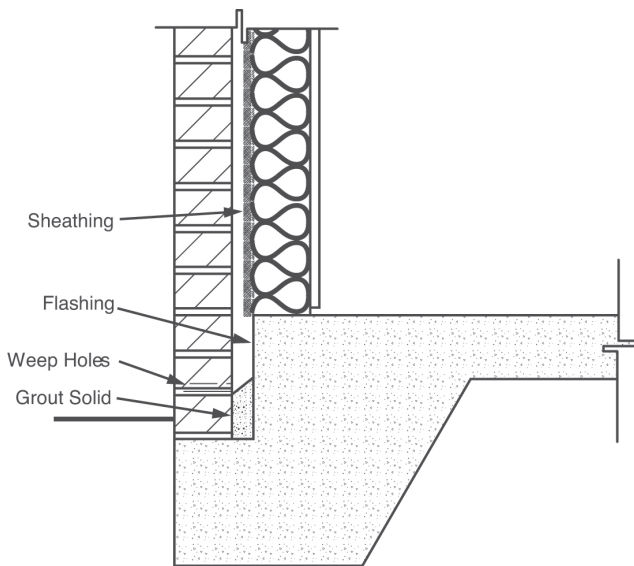

Detail 17 - Base of Wall

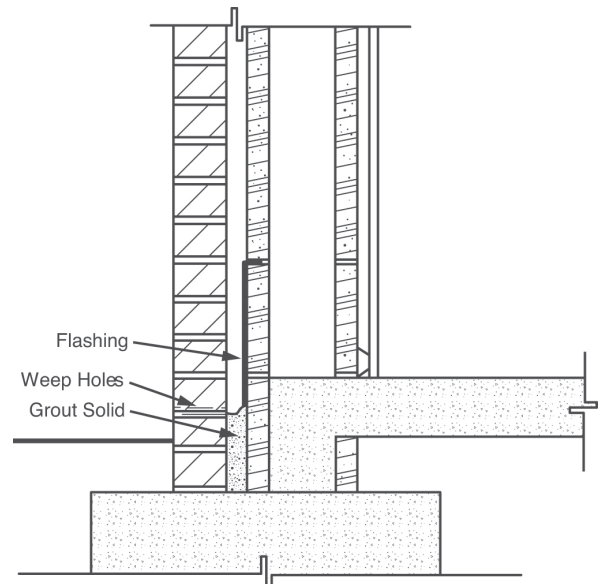

Detail 20 - Base of Wall



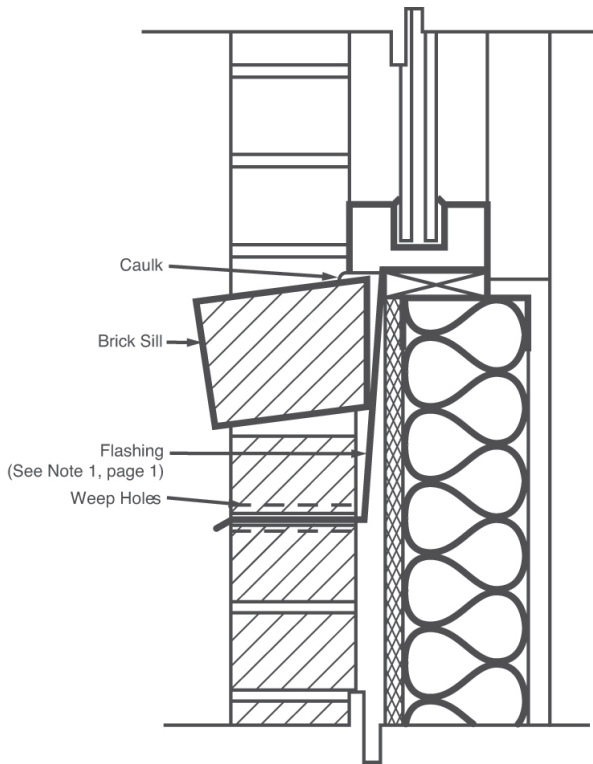

Detail 21 – Sill Detail W/ Brick Window Jambs

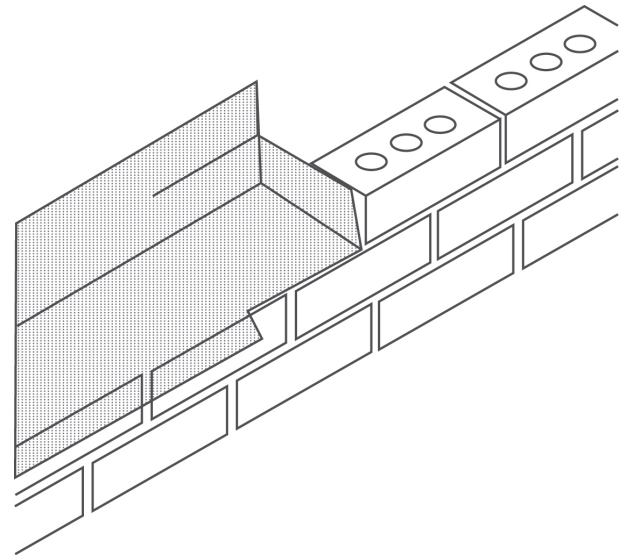

Flashing Termination at End of Sill  
(End Dam at Sill Detail)  
(See Note 1, page 1)

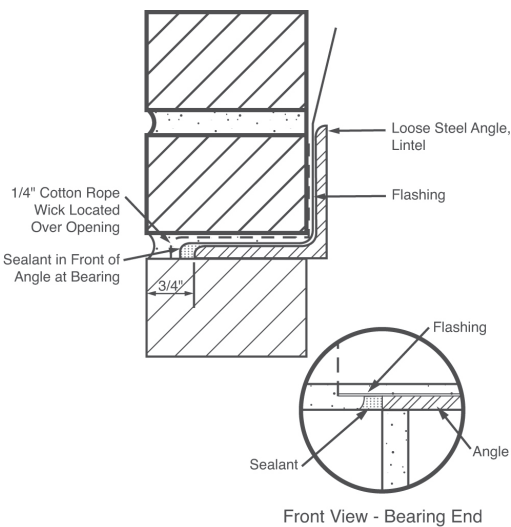

Detail 22 – Enlarged Flashing Detail at Lintel

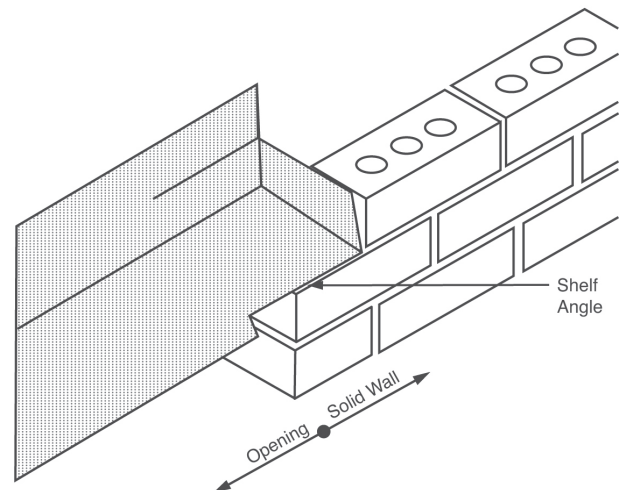

Flashing Termination at End of Lintel  
(End Dam on Lintel Detail)

Detail 23 – End Dams

Note: Sealant goes around the bearing end of the angle and provides a protective barrier from moisture.

Note: This detail may occur at windows, doors, and where shelf angle stops at vertical control joints.



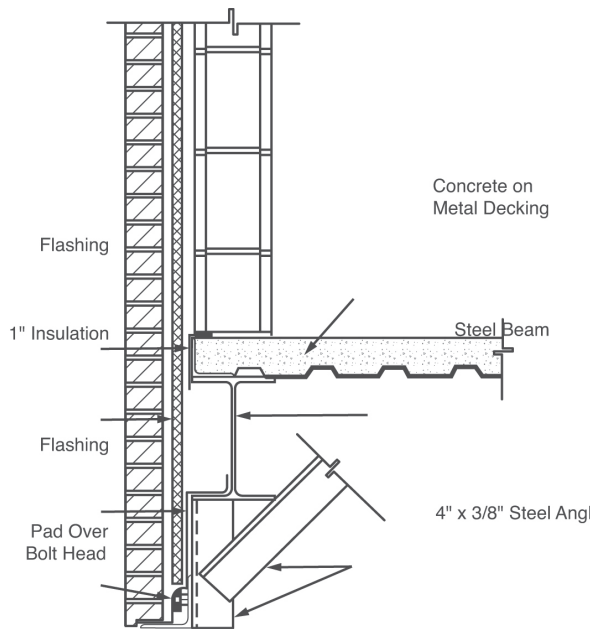

Detail 24 - Shelf Angle

Note: Brickwork supported on shelf angle positioned below support beam. Support beam could be concrete. Block backup could be metal studs. Anchors omitted for clarity.

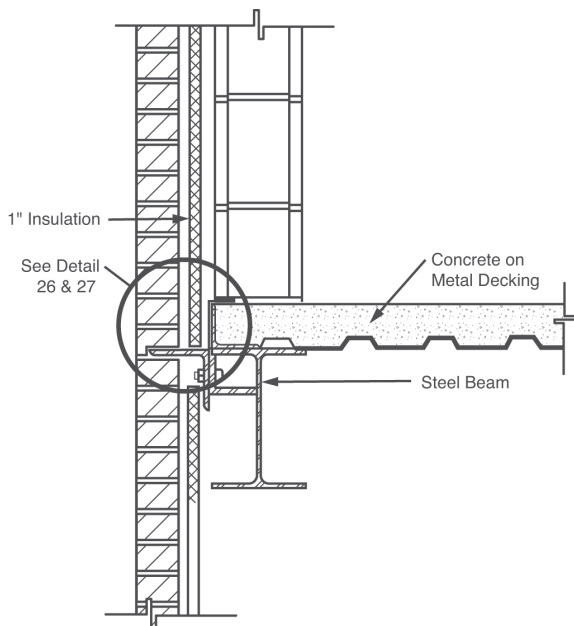

Detail 25 - Alternate Shelf Angle

Note: Anchors omitted for clarity.

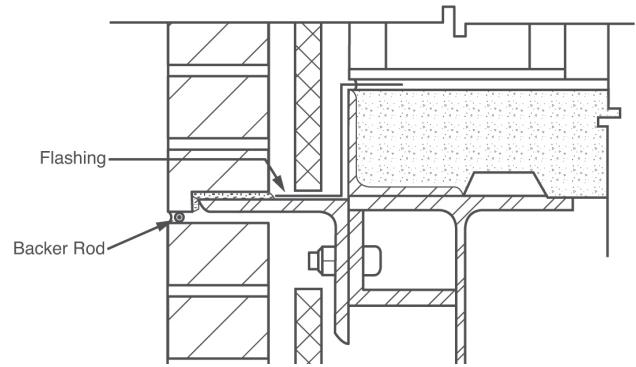

Detail 26 - Enlarged View of Shelf Angle

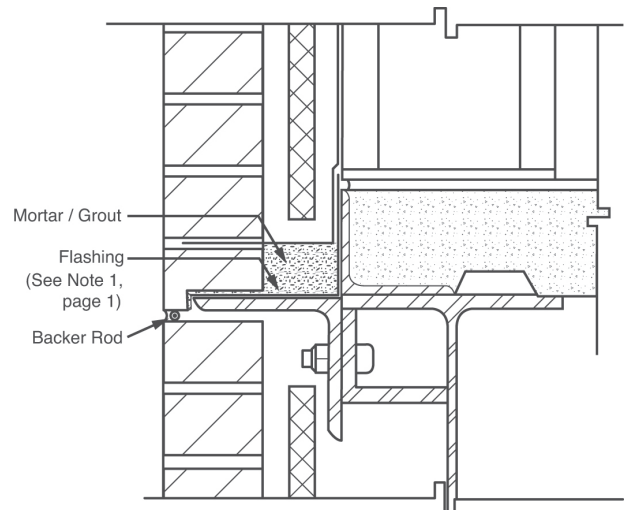

Detail 27 - Alternate to Detail 26

Note: Refer to note on "compatibility between flashing and sealant."

Coping Details, see next page.

**Coping Details**

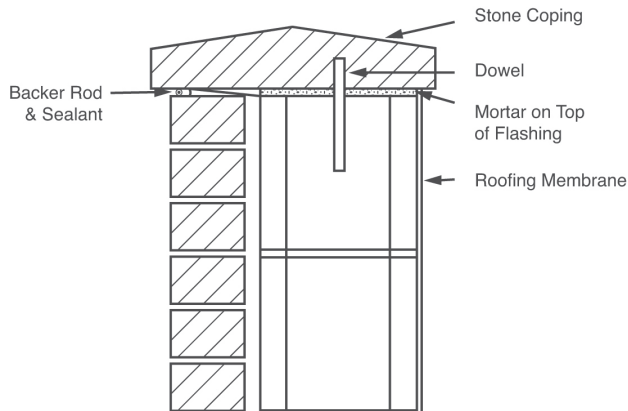

**Detail 28 - Stone Coping**

Note: Dowel which penetrates flashing must be sealed. Flashing at top of wall at corners must be lapped and sealed similar to detail 29. Mortar can replace backer rod & sealant on top of brick provided brick is supported by a shelf angle attached to building frame at the roof line. Flashing covering cavity should be composite /metal.

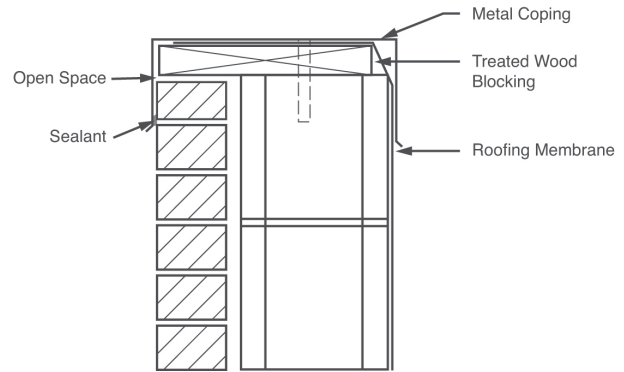

**Detail 30 - Metal Coping**

Note: This same detail may be used with metal studs as backup instead of concrete block.

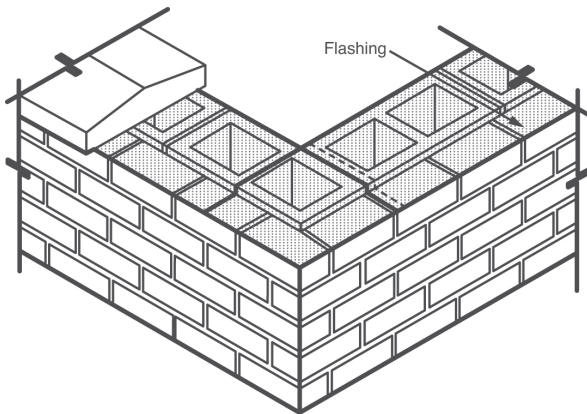

**Detail 29 - Corner Flashing**

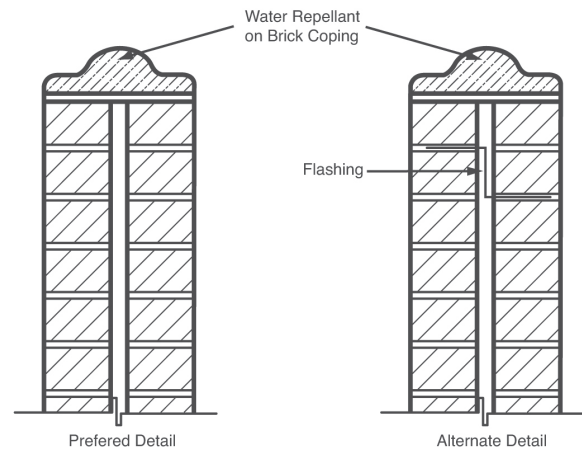

**Detail 31 - Garden Wall Coping**

Note: It is conservative to provide vertical control joints at approximately 20' - 0" to 25' - 0" (6 to 8 m). If flashing is installed, corners require the flashing to be lapped. Northern climates should have overhanging drip.